

1500 GALLON TRIPLE COMPARTMENT SEPTIC TANK

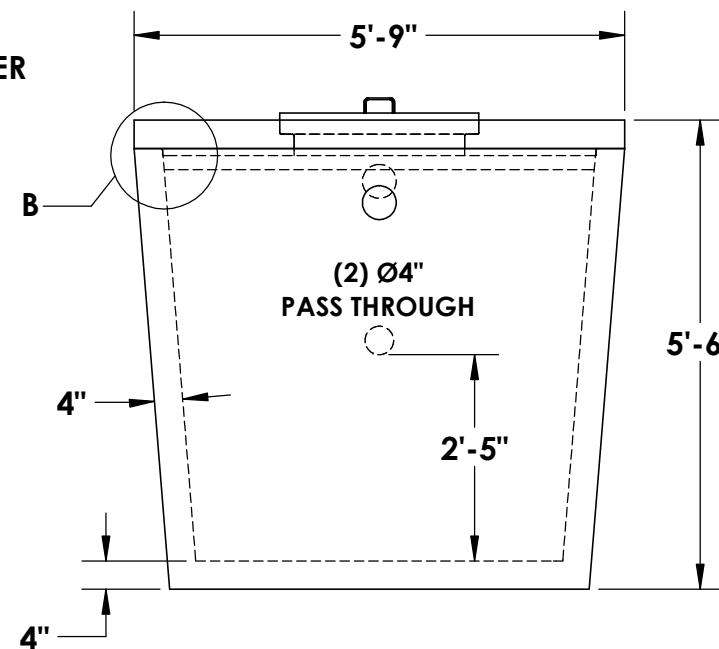
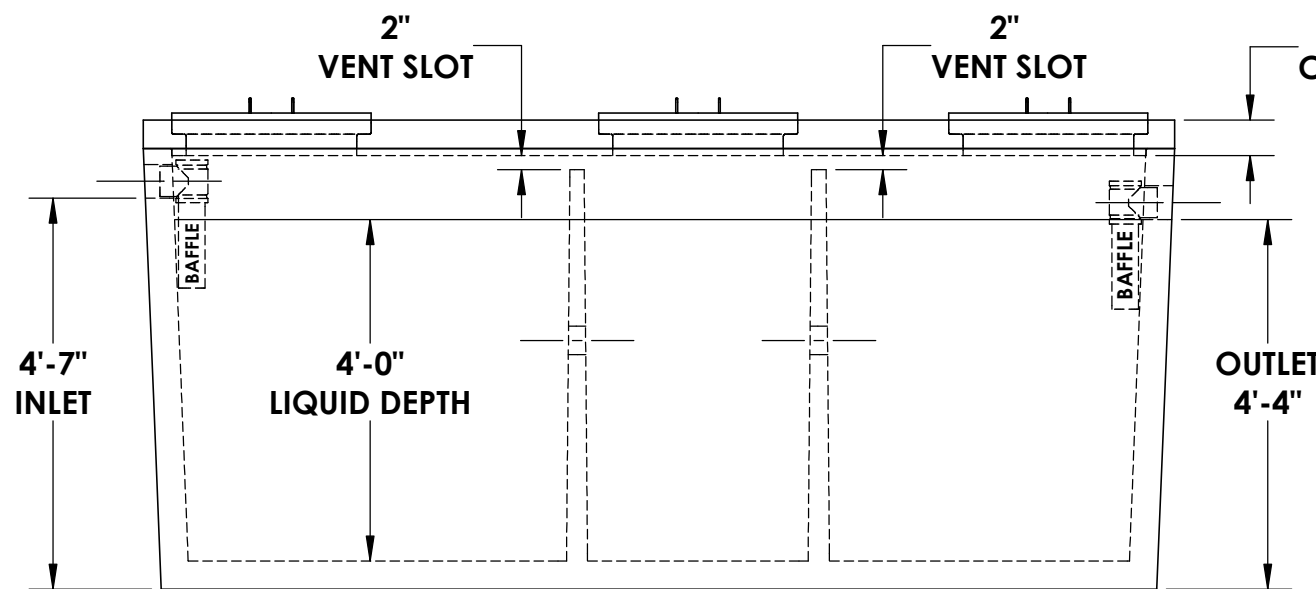
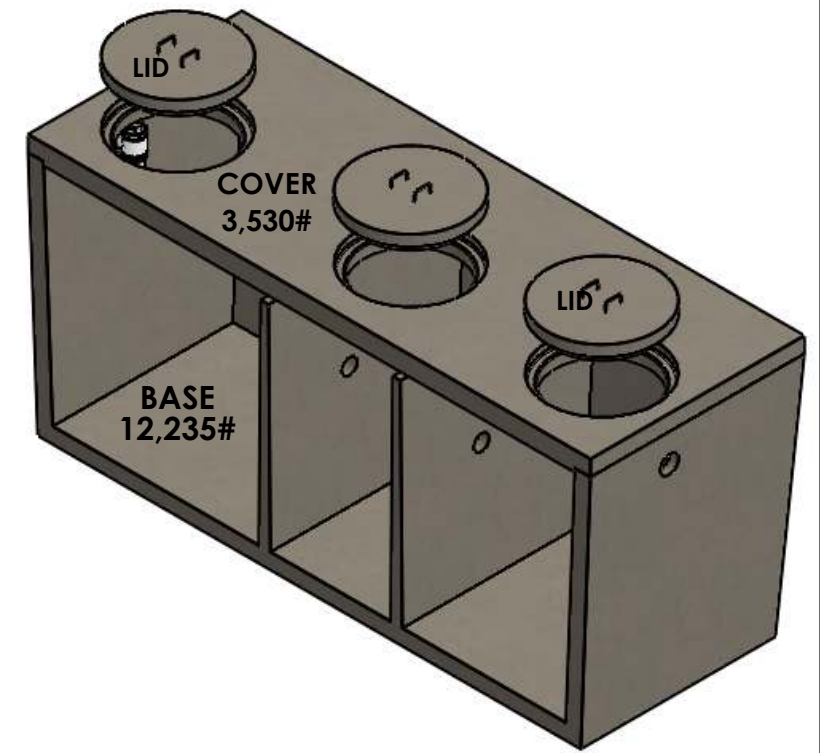
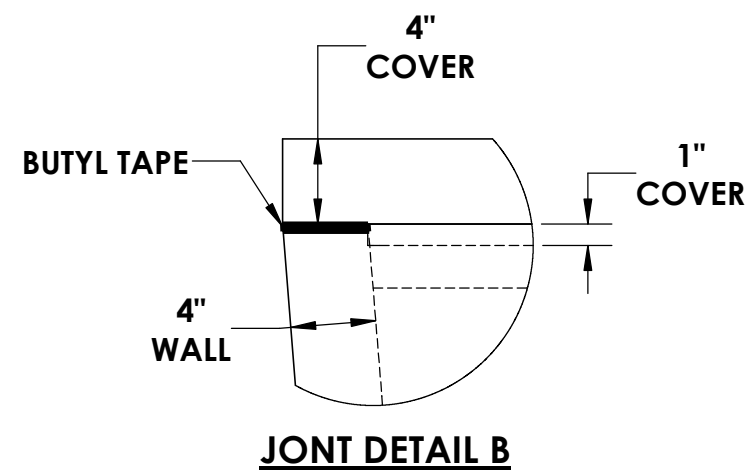
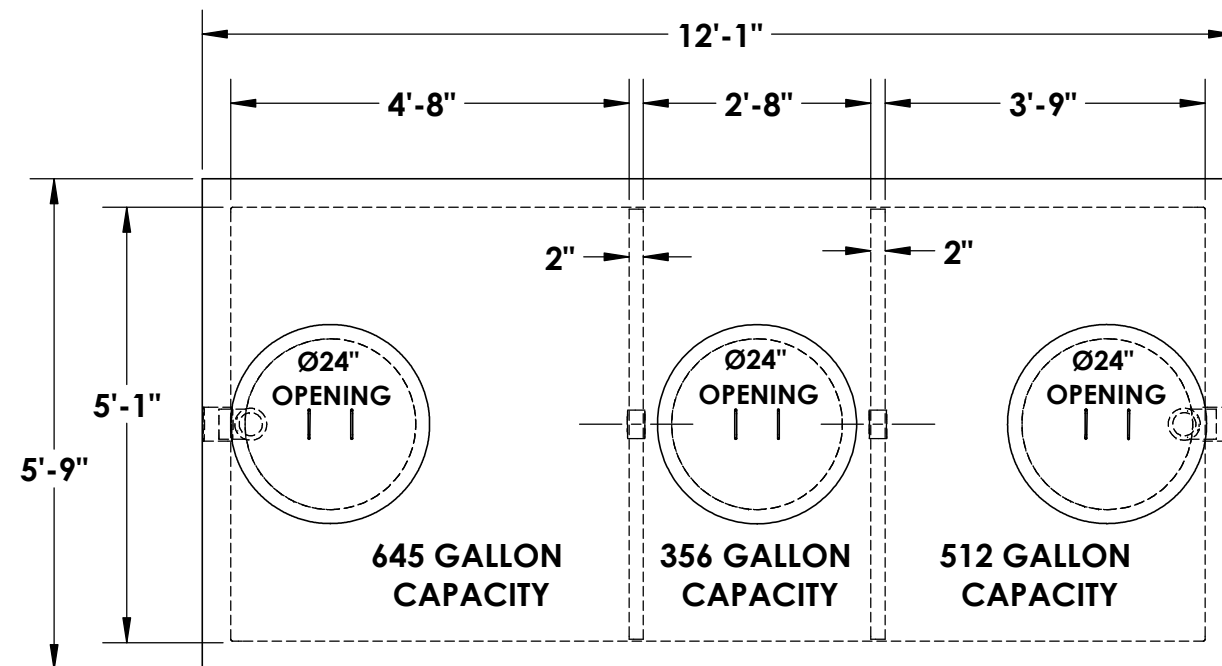

- * **CONCRETE:**
4,000 PSI MINIMUM
- * **REINFORCEMENT:**
WILL VARY UPON SIZE & TYPE
- * **RISER/FLANGE ADAPTERS:**
AVAILABLE UPON REQUEST

- NOTES:**
- ~ BEDDING MUST BE COMPACTED AND AREA AROUND TANK MUST BE BACKFILLED PRIOR TO PUTTING INTO SERVICE
 - ~ Ø4" PRESS SEAL BOOTS PROVIDED AT INLET & OUTLET
 - ~ STRUCTURAL ENGINEERING CALCULATIONS AVAILABLE UPON REQUEST
 - ~ 2-1/2" TAPER FROM TOP TO BOTTOM OF TANK

© INLAND NORTHWEST PRECAST 2018



INLAND NORTHWEST PRECAST

5516 NORTH STARR RD PO BOX 430, NEWMAN LAKE, WA 99025

*ALL TANKS ARE MADE IN ACCORDANCE WITH ASTM C1227 - 13 (STANDARD SPECIFICATION FOR PRECAST CONCRETE SEPTIC TANKS)