

SQUARE ADJUSTMENTS

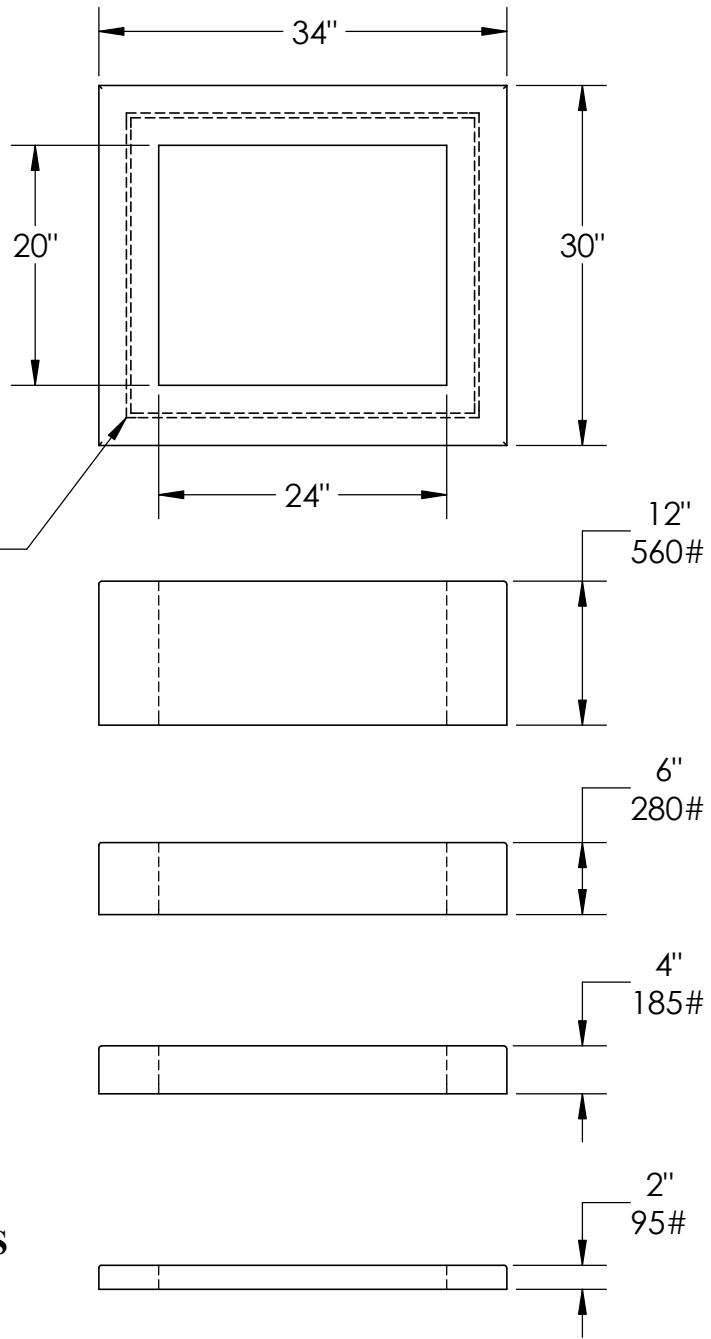

* SQUARE ADJUSTMENTS MEET
OR EXCEED THE REQUIREMENTS
OF ASTM C478/AASSTO M199,
ASTM C443, & ASTM C890.

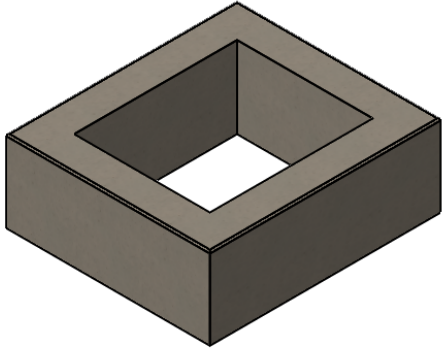

INLAND NORTHWEST PRECAST

5516 NORTH STARR RD PO BOX 610, NEWMAN LAKE, WA 99025 ~ (509) 226-5050