

# 1000 GALLON DOUBLE COMPARTMENT SEPTIC TANK

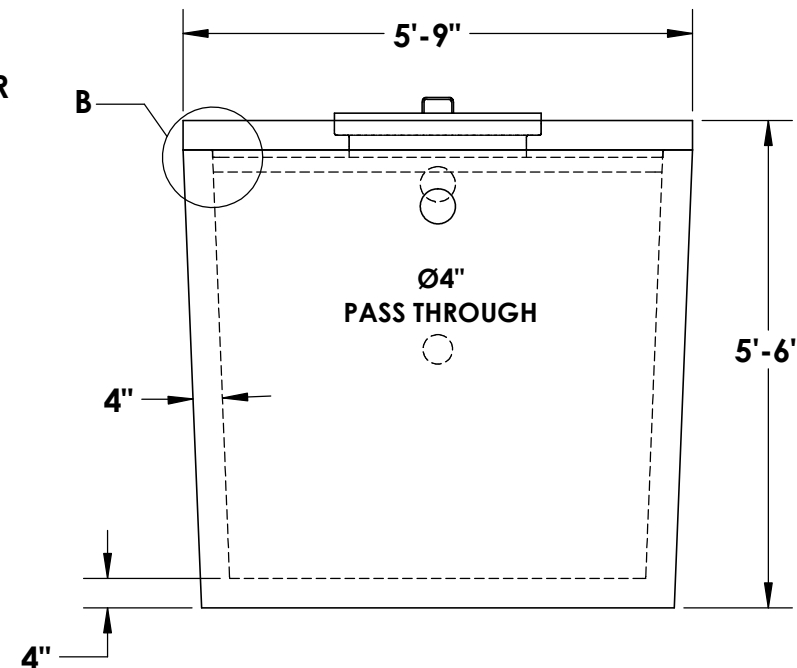
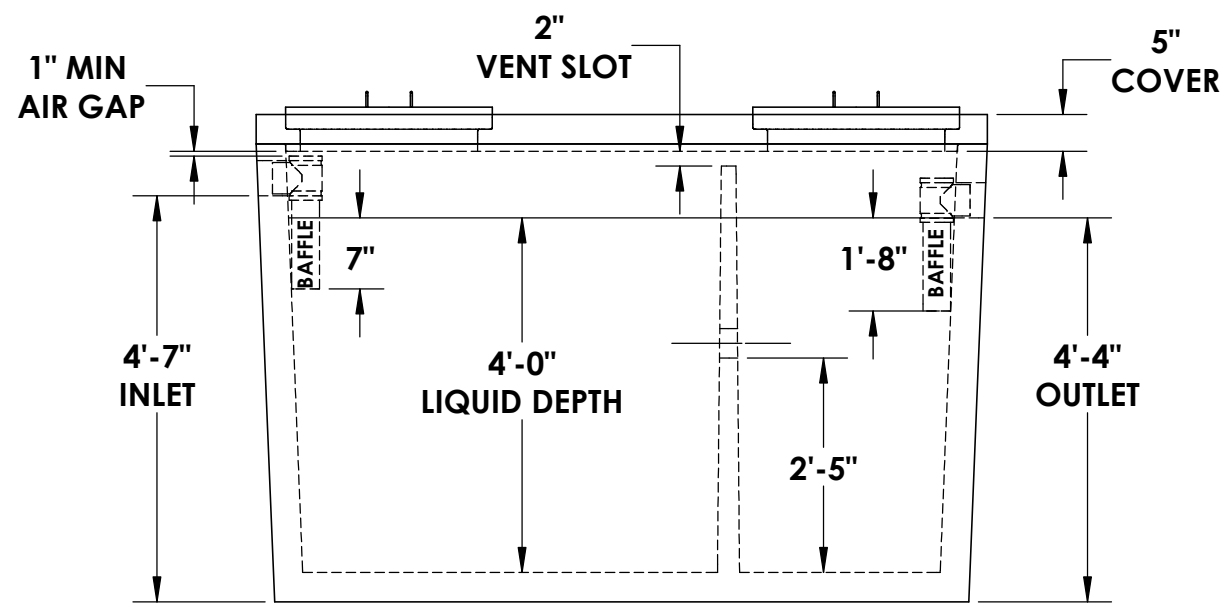
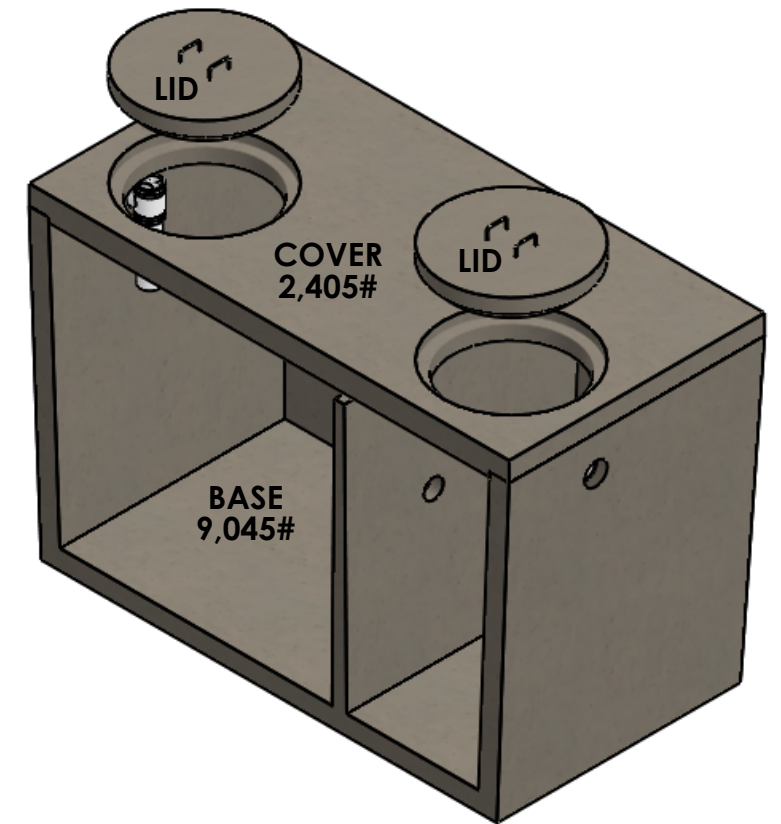
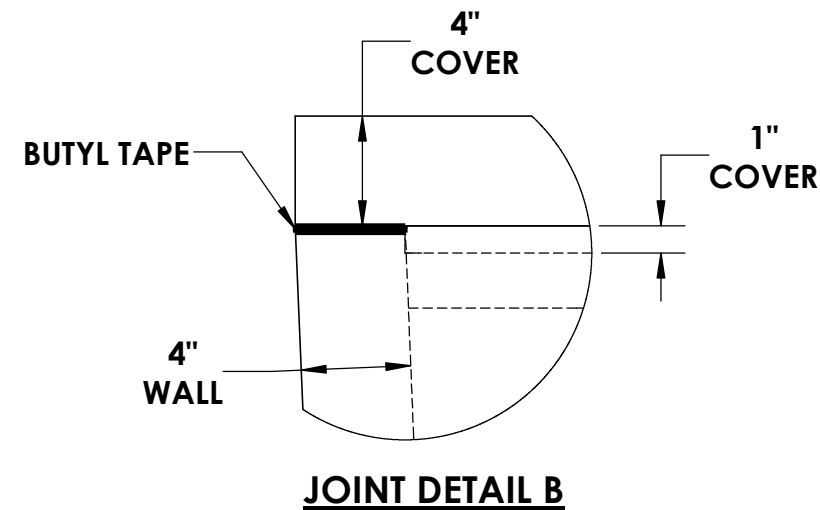
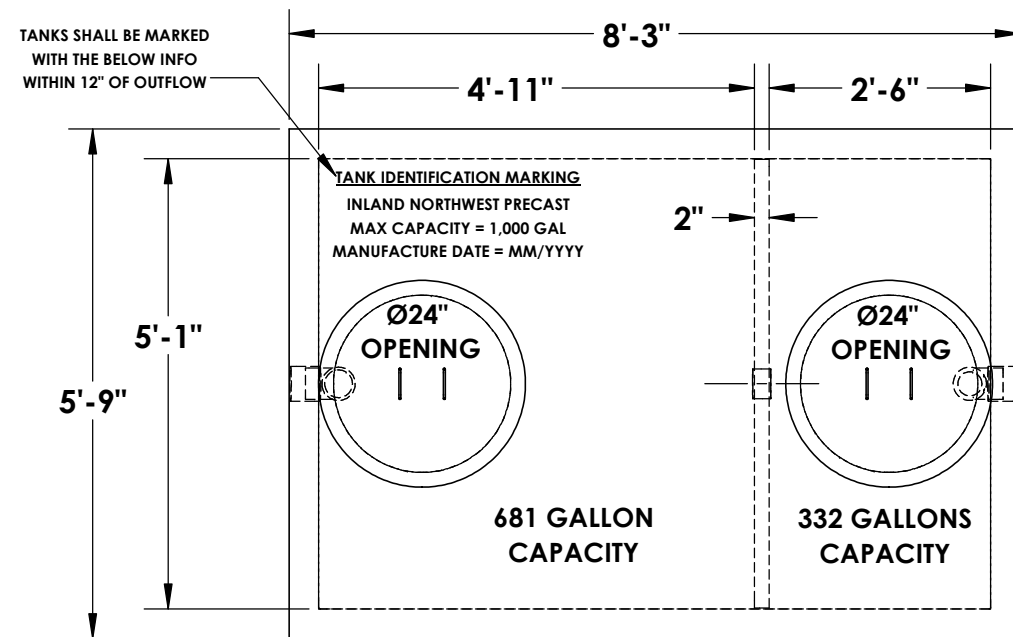

\* **CONCRETE:**  
4,000 PSI MINIMUM

\* **RISER/FLANGE ADAPTERS:**  
AVAILABLE UPON REQUEST

**NOTES:**

- ~ BEDDING MUST BE COMPACTED AND AREA AROUND TANK MUST BE BACKFILLED PRIOR TO PUTTING INTO SERVICE
- ~ Ø4" PRESS SEAL BOOTS PROVIDED AT INLET & OUTLET
- ~ STRUCTURAL ENGINEERING CALCULATIONS AVAILABLE UPON REQUEST
- ~ 2-1/2" TAPER FROM TOP TO BOTTOM OF TANK

© INLAND NORTHWEST PRECAST 2018



## INLAND NORTHWEST PRECAST

5516 NORTH STARR RD PO BOX 610, NEWMAN LAKE, WA 99025 ~ (509) 226-5050 ~ [www.inwprecast.com](http://www.inwprecast.com)



**REINFORCEMENT:**

- ~ LID  
TRANSV. - #4 @ 6"  
LONGIT. - #4 @ 1'-0"
- ~ WALLS  
4x4W4xW4 THROUGHOUT
- ~ BASE  
TRANSV. - #4 @ 9"  
LONGIT. - #4 @ 12"

\* ALL TANKS ARE MADE IN ACCORDANCE WITH ASTM C1227 - 13 (STANDARD SPECIFICATION FOR PRECAST CONCRETE SEPTIC TANKS)