

# CITY OF SPOKANE TYPE 1 CATCH BASIN

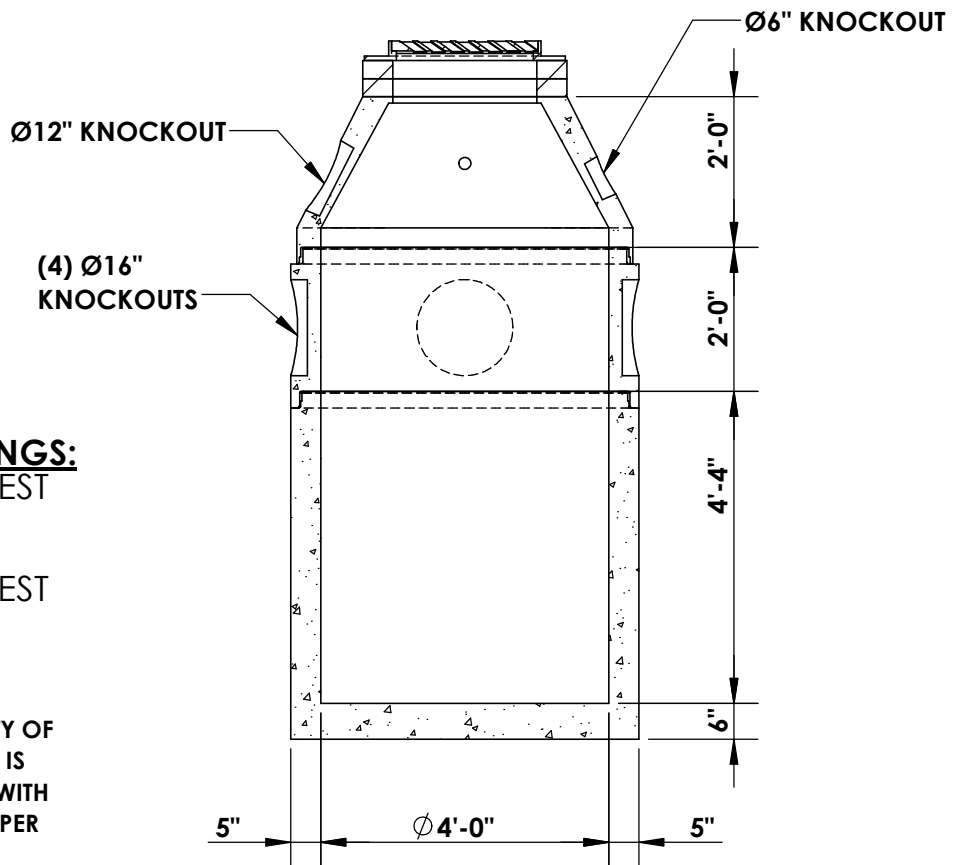
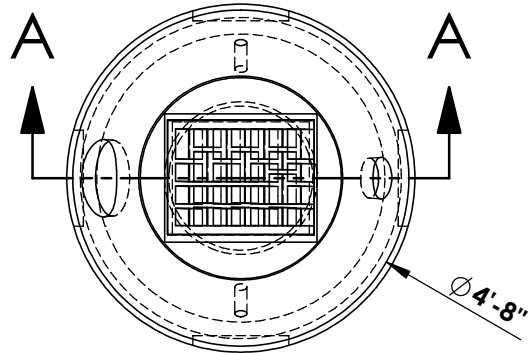
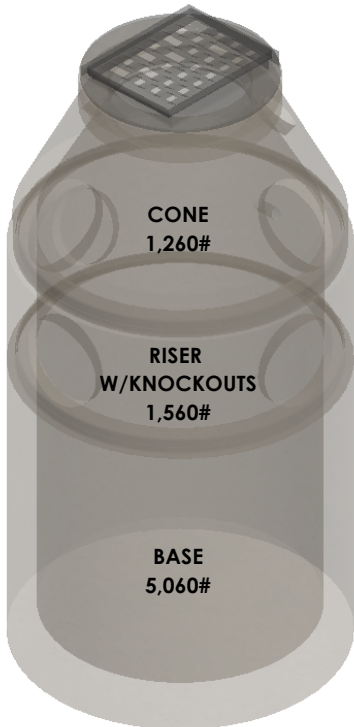

SECTION A-A

\* **CONCRETE:**  
4,000 PSI MIN.

\* **ROUND ADJUSTMENT RINGS:**  
AVAILABLE UPON REQUEST

\* **CAST-IRON**  
AVAILABLE UPON REQUEST

~ STRUCTURE MEETS OR EXCEEDS CITY OF SPOKANE STANDARD B-101C AND IS CONSTRUCTED IN ACCORDANCE WITH WITH ASTM C858 & AASHTO M199 PER WSDOT SPEC. 9-05.50(1)



## INLAND NORTHWEST PRECAST



5516 NORTH STARR RD PO BOX 610, NEWMAN LAKE, WA 99025 ~ (509) 226-5050 ~ [www.inwprecast.com](http://www.inwprecast.com)