

# TYPE 2 CONCRETE INLET

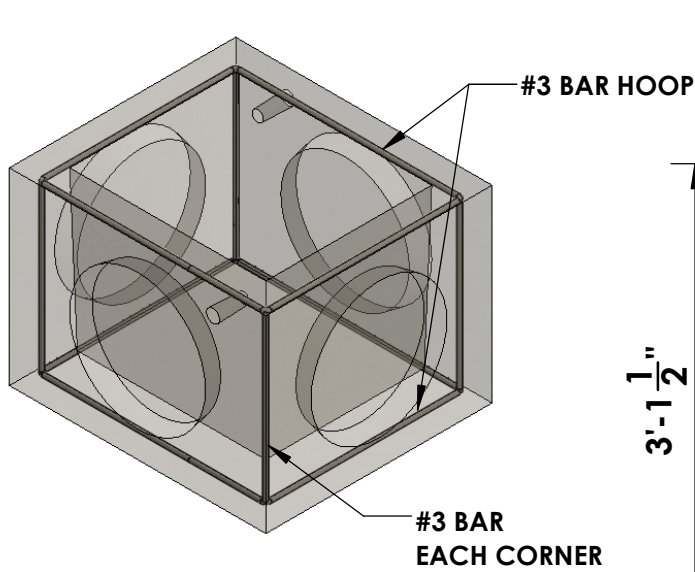

**WEIGHT: 1,360#**

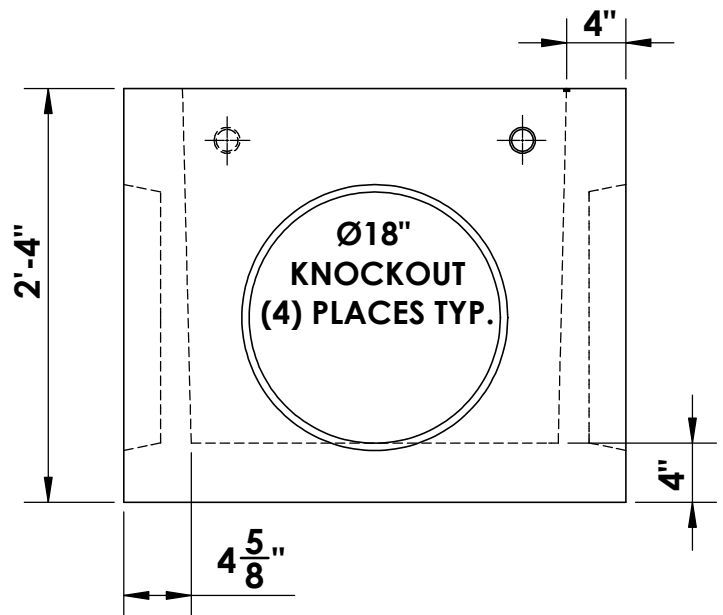
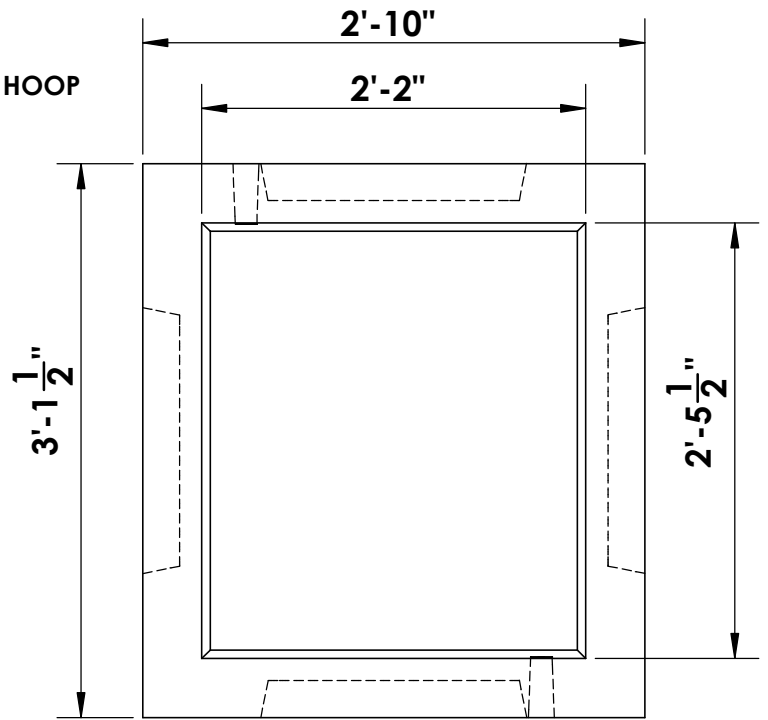

\* CONCRETE:  
4,000 PSI MIN.

\* SQUARE GRADE ADJUSTMENT RINGS:  
AVAILABLE UPON REQUEST

\* CAST-IRON FRAME & GRATE:  
AVAILABLE UPON REQUEST

~ STRUCTURE MEETS OR EXCEEDS SPOKANE COUNTY STANDARD PLAN B-6 AND IS CONSTRUCTED IN ACCORDANCE WITH ASTM C858



## INLAND NORTHWEST PRECAST



5516 NORTH STARR RD PO BOX 610, NEWMAN LAKE, WA 99025 ~ (509) 226-5050 ~ [www.inwprecast.com](http://www.inwprecast.com)