

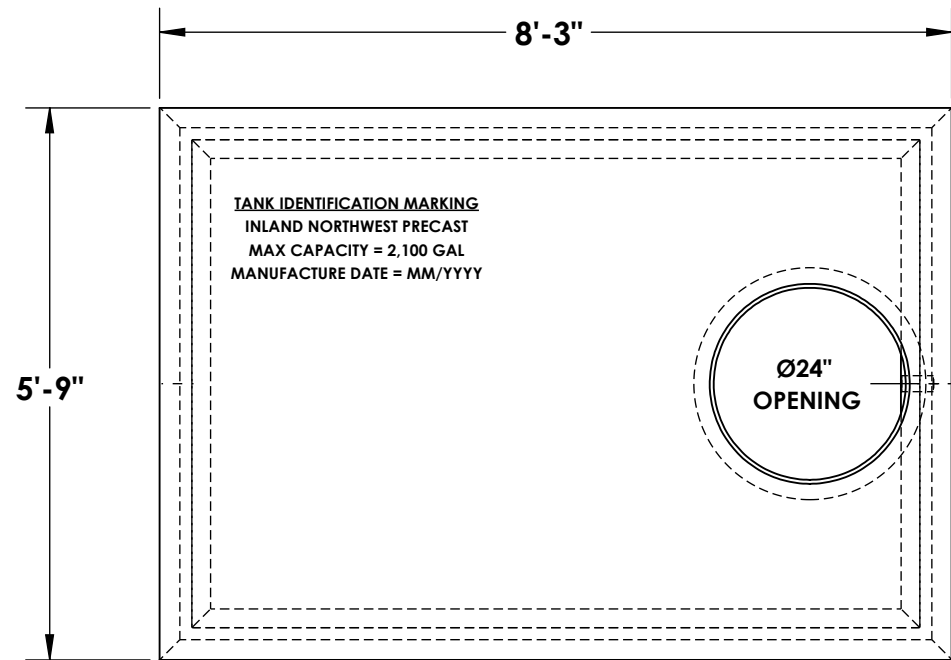

# 1200 GALLON WATER TANK



### REINFORCEMENT:

- ~ LID  
TRANSV. - #4 @ 6"  
LONGIT. - #4 @ 6"
- ~ WALLS  
4x4W4xW4 THROUGHOUT
- ~ BASE  
TRANSV. - #4 @ 9"  
LONGIT. - #4 @ 12"

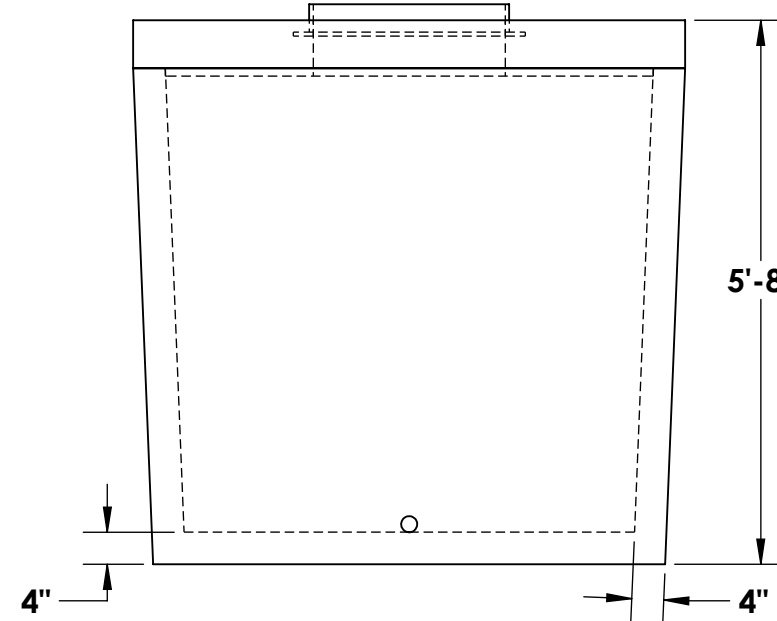
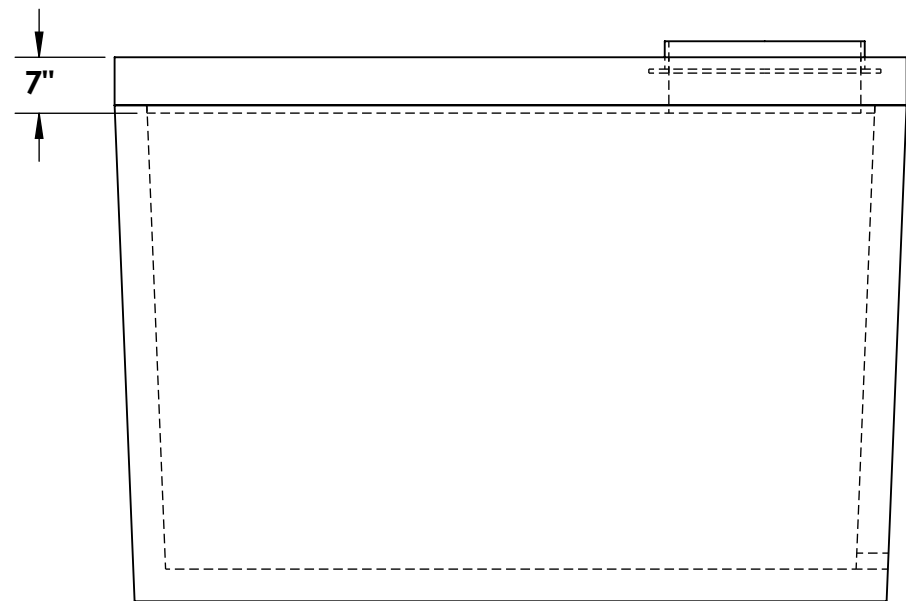
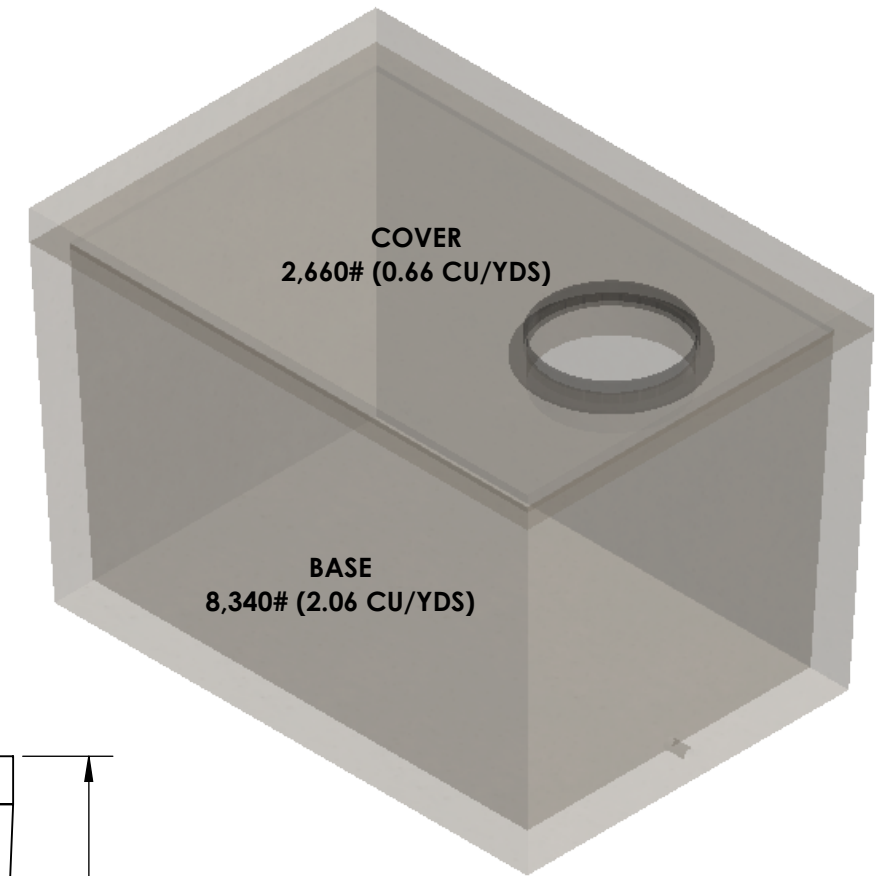

\* **CONCRETE:**  
4,000 PSI MINIMUM

\* **RISER/FLANGE ADAPTERS:**  
AVAILABLE UPON REQUEST

### NOTES:

- ~ BEDDING MUST BE COMPACTED AND AREA AROUND TANK MUST BE BACKFILLED PRIOR TO PUTTING INTO SERVICE
- ~ STRUCTURAL ENGINEERING CALCULATIONS AVAILABLE UPON REQUEST
- ~ 2-1/2" TAPER FROM TOP TO BOTTOM OF TANK



5204 NORTH STARR RD PO BOX 610  
NEWMAN LAKE, WA 99025  
(509) 226-5050  
www.inwprecast.com



\*ALL TANKS ARE MADE IN ACCORDANCE WITH ASTM C1227 - 13 (STANDARD SPECIFICATION FOR PRECAST CONCRETE SEPTIC TANKS)