

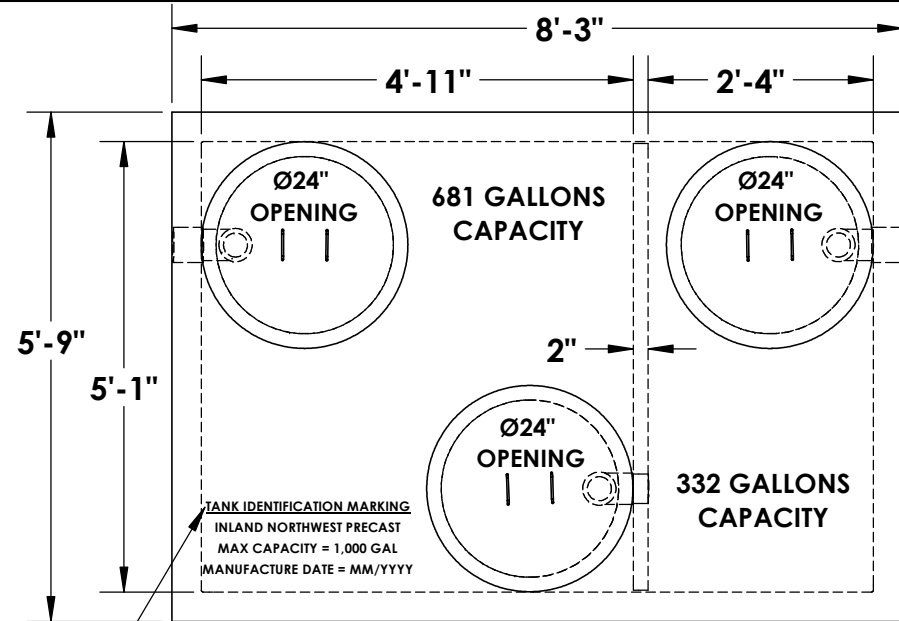

# 1000 GALLON GREASE INTERCEPTOR

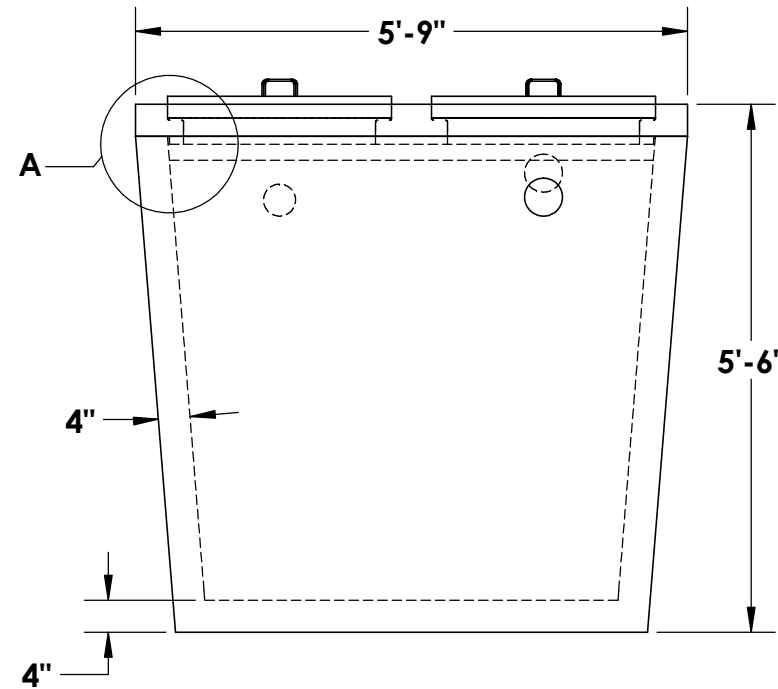

TANKS SHALL BE MARKED WITH THE ABOVE INFO WITHIN 12" OF OUTFLOW

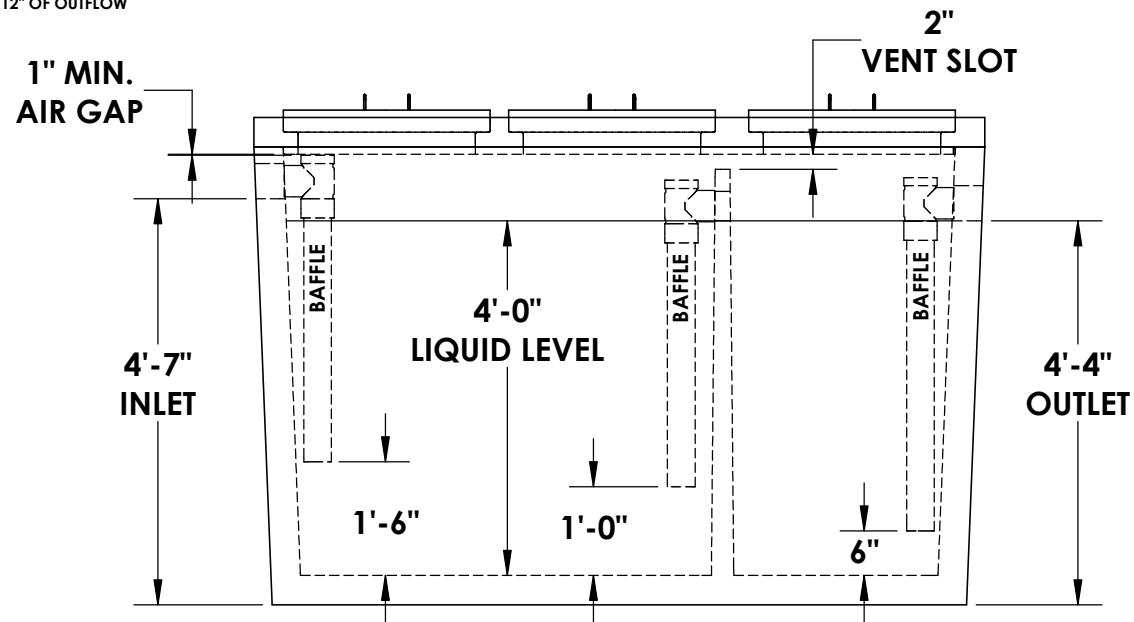
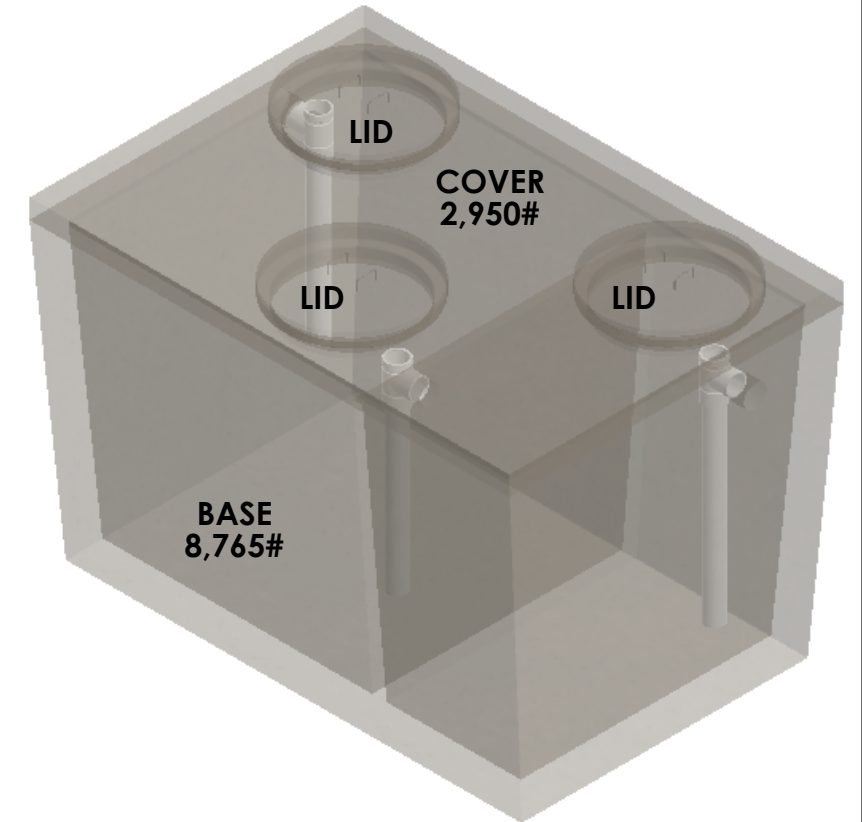
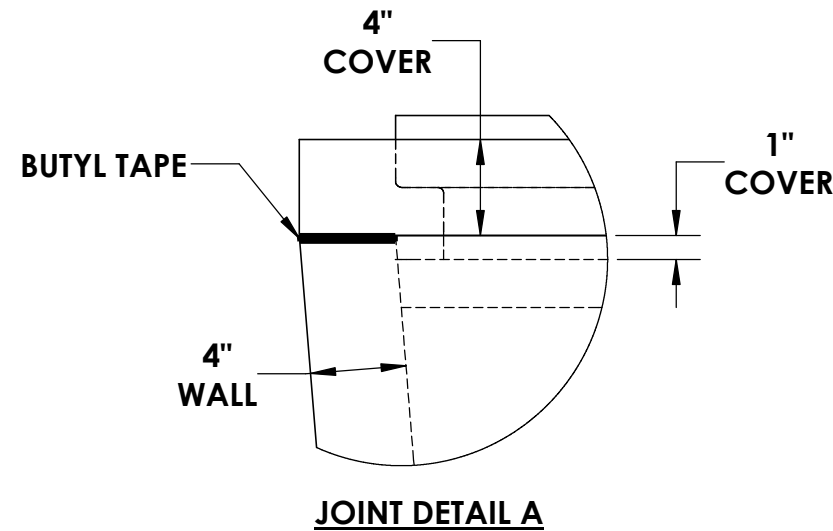

- \* CONCRETE:  
4,000 PSI MINIMUM
- \* RISER/FLANGE ADAPTERS:  
AVAILABLE UPON REQUEST

- NOTES:**
- ~ BEDDING MUST BE COMPACTED AND AREA AROUND TANK MUST BE BACKFILLED PRIOR TO PUTTING INTO SERVICE
  - ~ Ø4" PRESS SEAL BOOTS PROVIDED AT INLET & OUTLET
  - ~ STRUCTURAL ENGINEERING CALCULATIONS AVAILABLE UPON REQUEST
  - ~ 2-1/2" TAPER FROM TOP TO BOTTOM OF TANK

© INLAND NORTHWEST PRECAST



5204 NORTH STARR RD PO BOX 610  
 NEWMAN LAKE, WA 99025  
 (509) 226-5050  
 www.inwprecast.com



- REINFORCEMENT:**
- ~ LID  
TRANSV. - #4 @ 6"  
LONGIT. - #4 @ 1'-0"
  - ~ WALLS  
4x4W4xW4 THROUGHOUT
  - ~ BASE  
TRANSV. - #4 @ 9"  
LONGIT. - #4 @ 12"

\*ALL TANKS ARE MADE IN ACCORDANCE WITH ASTM C1227 - 13 (STANDARD SPECIFICATION FOR PRECAST CONCRETE SEPTIC TANKS)



# 1000 GALLON TRAFFIC RATED GREASE INTERCEPTOR SPOKANE COUNTY

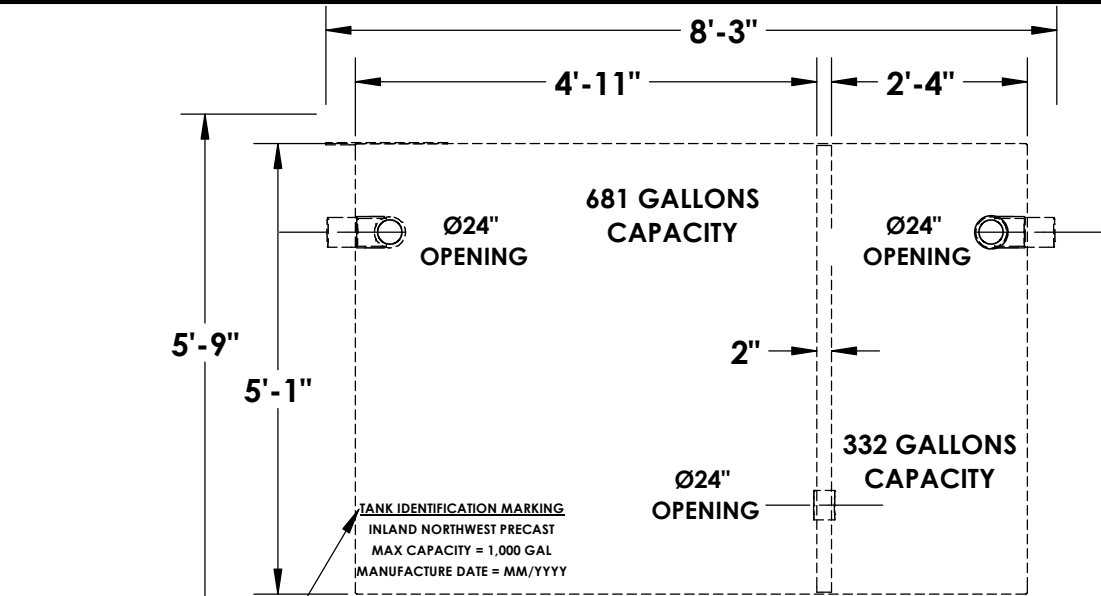

TANKS SHALL BE MARKED WITH THE ABOVE INFO WITHIN 12" OF OUTFLOW

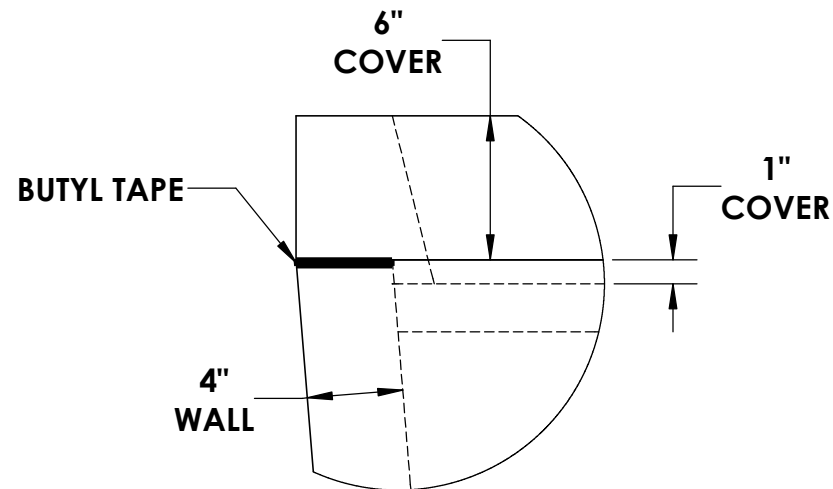

**JOINT DETAIL A**

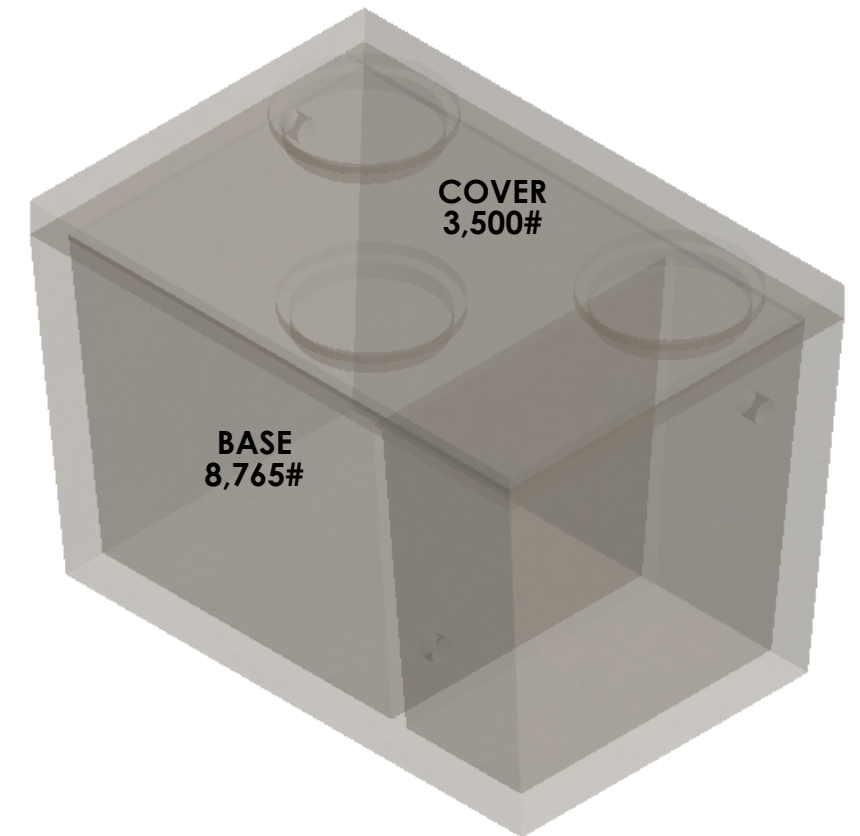

\* **CONCRETE:**  
4,000 PSI MINIMUM

\* **RISER/FLANGE ADAPTERS:**  
AVAILABLE UPON REQUEST

**NOTES:**

- ~ BEDDING MUST BE COMPACTED AND AREA AROUND TANK MUST BE BACKFILLED PRIOR TO PUTTING INTO SERVICE
- ~ STRUCTURAL ENGINEERING CALCULATIONS AVAILABLE UPON REQUEST
- ~ 2-1/2" TAPER FROM TOP TO BOTTOM OF TANK

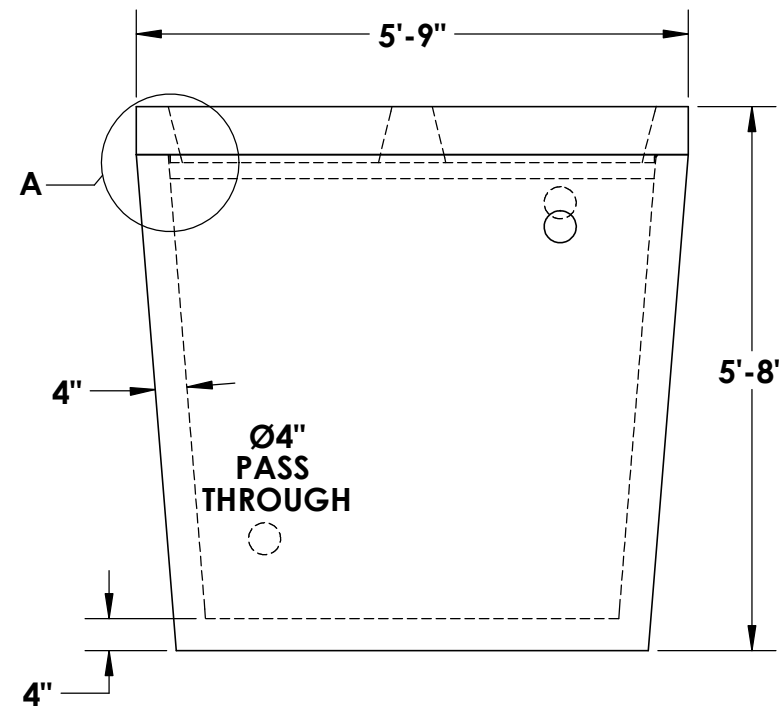
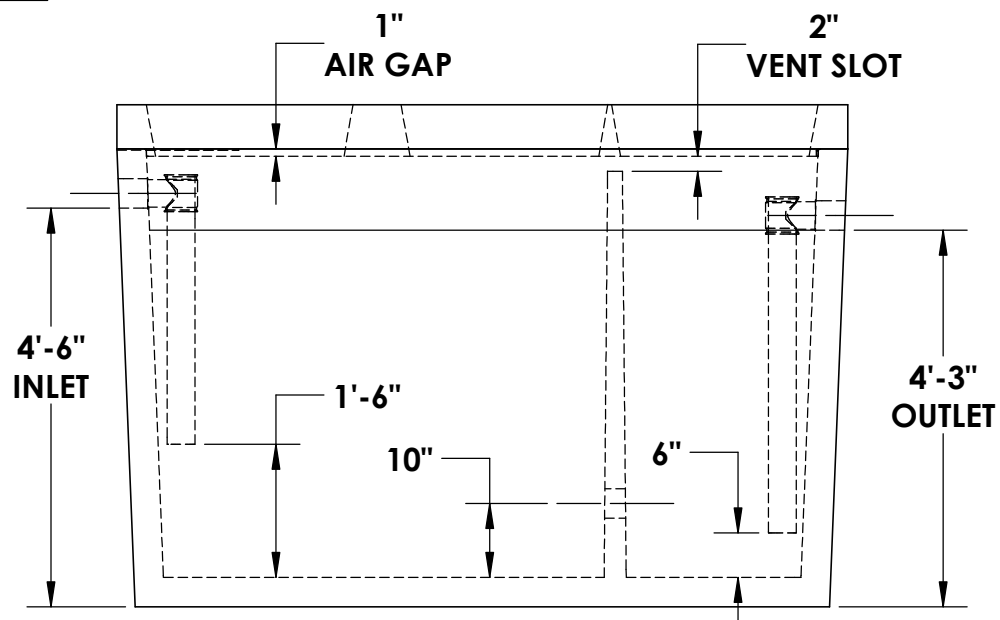

5204 NORTH STARR RD PO BOX 610  
NEWMAN LAKE, WA 99025  
(509) 226-5050  
www.inwprecast.com



**REINFORCEMENT:**

- ~ LID  
TRANSV. - #4 @ 6"  
LONGIT. - #4 @ 1'-0"
- ~ WALLS  
4x4W4xW4 THROUGHOUT
- ~ BASE  
TRANSV. - #4 @ 9"  
LONGIT. - #4 @ 12"

\*ALL TANKS ARE MADE IN ACCORDANCE WITH ASTM C1227 - 13 (STANDARD SPECIFICATION FOR PRECAST CONCRETE SEPTIC TANKS)



# 1000 GALLON GREASE INTERCEPTOR - TRAFFIC RATED

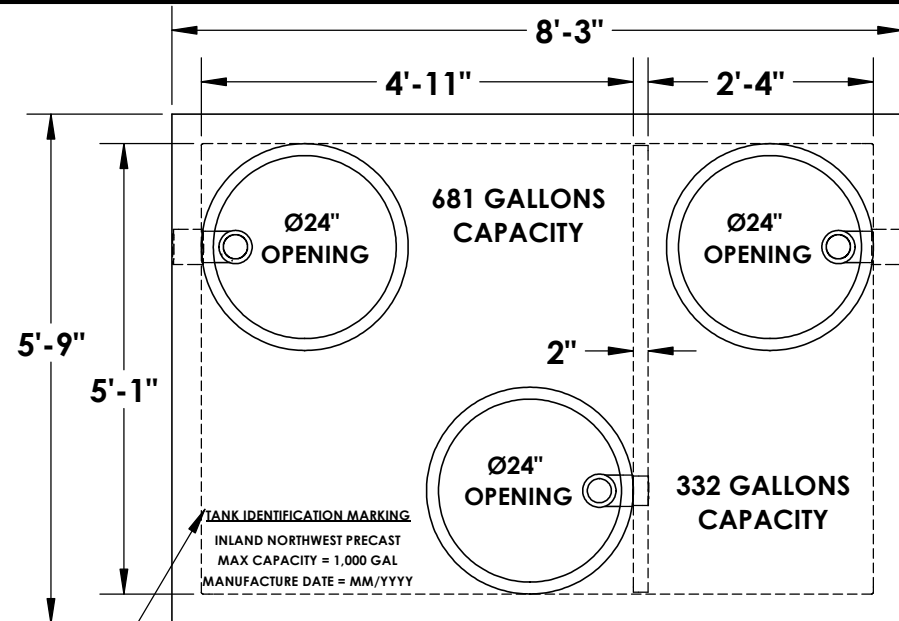

TANKS SHALL BE MARKED WITH THE ABOVE INFO WITHIN 12" OF OUTFLOW

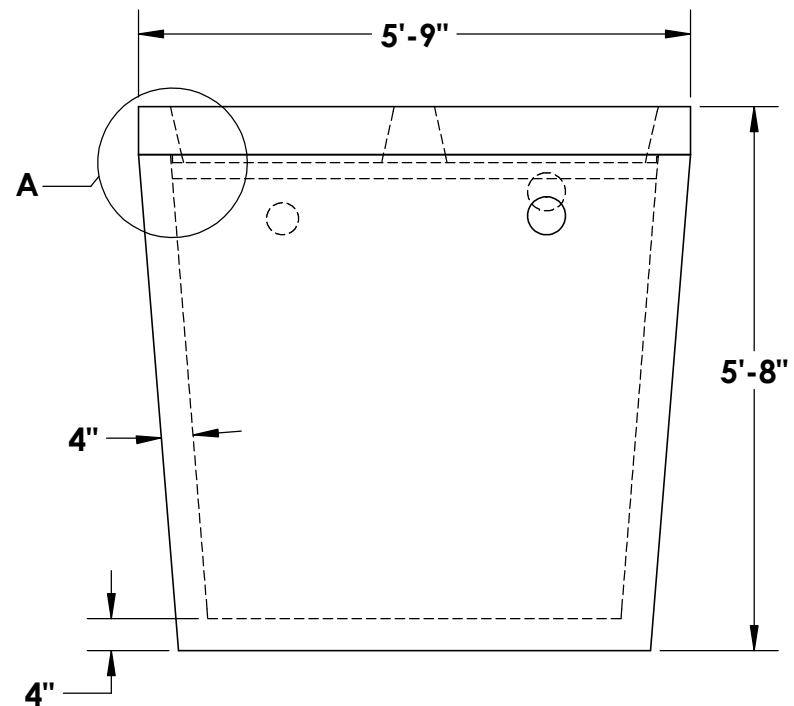
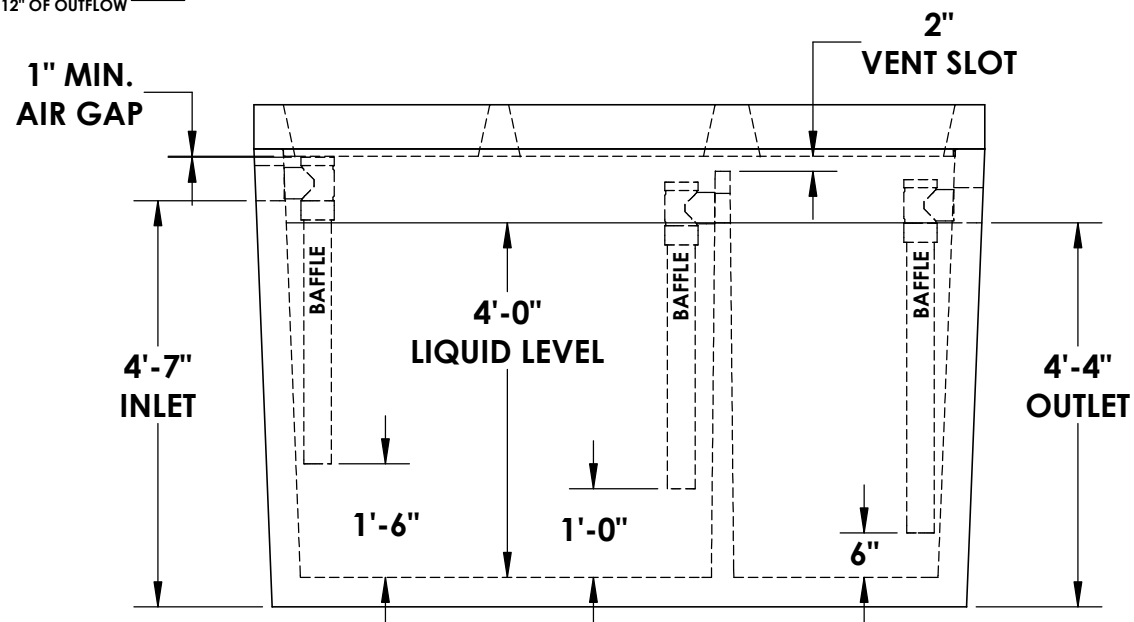
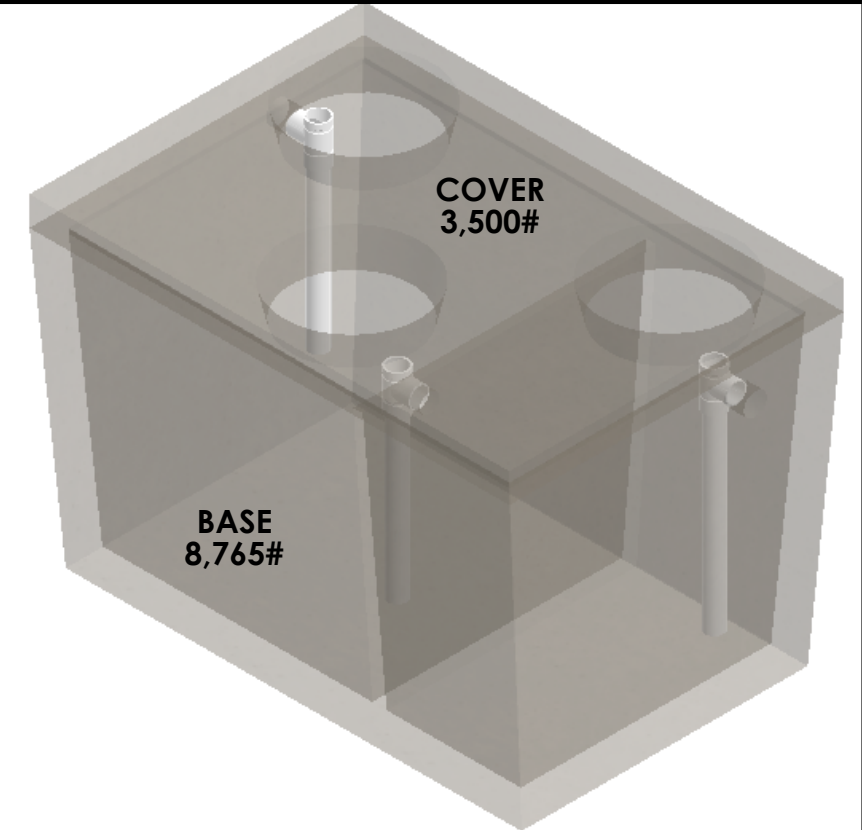
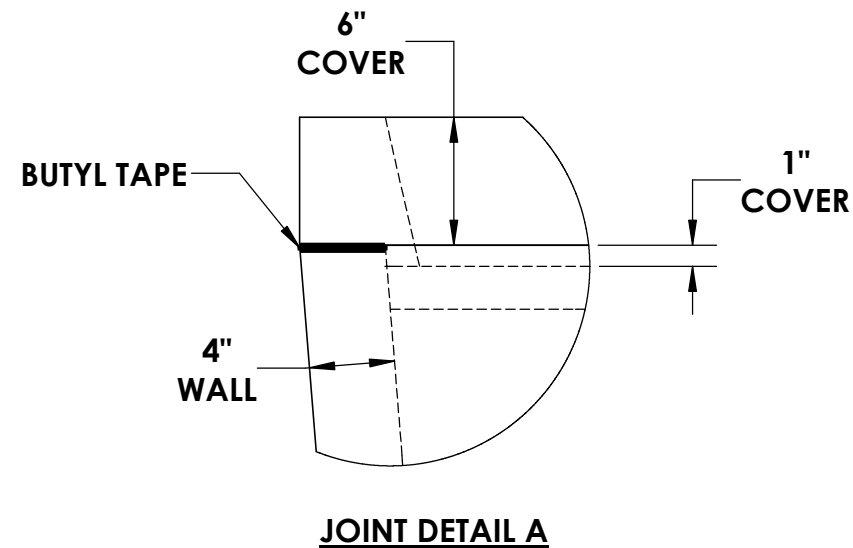

\* **CONCRETE:**  
4,000 PSI MINIMUM

\* **RISER/FLANGE ADAPTERS:**  
AVAILABLE UPON REQUEST

**NOTES:**

- ~ BEDDING MUST BE COMPACTED AND AREA AROUND TANK MUST BE BACKFILLED PRIOR TO PUTTING INTO SERVICE
- ~ Ø4" PRESS SEAL BOOTS PROVIDED AT INLET & OUTLET
- ~ STRUCTURAL ENGINEERING CALCULATIONS AVAILABLE UPON REQUEST
- ~ 2-1/2" TAPER FROM TOP TO BOTTOM OF TANK

© INLAND NORTHWEST PRECAST



5204 NORTH STARR RD PO BOX 610  
NEWMAN LAKE, WA 99025  
(509) 226-5050  
www.inwprecast.com



**REINFORCEMENT:**

- ~ LID  
TRANSV. - #4 @ 6"  
LONGIT. - #4 @ 1'-0"
- ~ WALLS  
4x4W4xW4 THROUGHOUT
- ~ BASE  
TRANSV. - #4 @ 9"  
LONGIT. - #4 @ 12"

\*ALL TANKS ARE MADE IN ACCORDANCE WITH ASTM C1227 - 13 (STANDARD SPECIFICATION FOR PRECAST CONCRETE SEPTIC TANKS)